



# LED Solar Street Light

PRODUCTS SPECIFICATION



BB-SLD-XXX-A2



Highlight LED



Single silicon Solar panel



Lithium iron phosphate battery



Remote control



Heat dissipation performance



Waterproof

## Product description

\*Solar energy is a kind of green renewable and clean energy that is pollution-free, noise-free, inexhaustible and inexhaustible. When the solar panel receives sunlight, it can generate photovoltaic effect to generate electric energy, and the controller stores the electric energy into the battery. Night battery discharge lights LED light source, charging night use, one-time investment, multi-year benefits.

\*The company's patented product adopts the integrated design of A-type Sanyuanli battery pack and lamp body controller.

\*Fully automatic intelligent light control, time control, remote control function, charging during the day and automatically lighting at night.

\*It adopts one-piece aluminum casing, imported high-efficiency light source, full power solar panel, anti-corrosion, waterproof and lightning protection.

\*This product is specially designed for outdoor outdoor lighting, easy to install. Solar power supply, 0 wiring, nail wall, pole, holding cement column and other installation methods.

\*Suitable for highways, town roads, street lights, rural roads, park lights, courtyard lighting, channel lighting, farms, etc.

\*This product solar panel energy efficiency conversion rate of 18% or more, normal sunshine charging more than 8 hours, can supply 3-4 rainy days. Evening (12 hours per night). High temperature resistance 80 degrees, low temperature resistance minus 20 degrees.

## SPECIFICATIONS

Power	50W	80W	100W
Model	BB-SLD-50W-A2	BB-SLD-80W-A2	BB-SLD-100W-A2
Solar panel Max power	18/40W	18/50W	18/70W
lamp size	615*365*160mm	720*365*160mm	930*365*160mm
Radiation range	40m <sup>2</sup>	60m <sup>2</sup>	80m <sup>2</sup>
Mounting Height	3-4m	5-6m	6-7m
LED QTY	96pcs	144pcs	192pcs
Battery(Lithium battery)	12.8V/12AH	12.8V/18AH	12.8V/24AH
Sensor	Motion Sensor, Photocell Sensor		
Controller	PWM controller, MPPT controller optional		
Material	High quality Aluminium alloy housing		
Discharge Time	More than 12hours		
Charge Time	6-8hours(with enough strong shine)		
Solar Cell	High efficiency Single silicon Solar panel		
Light Source	SMD LED		
Operation Temp.	-40 to +45°C		
CCT	2700K SW / 3000K WW / 4100K NW / 5000K DW / 5700K CW		
CRI	70+		
Material	Metal alloy+PC lens		
Colour	Silver \ bronze (Customized)		
Life Span	50,000 hours		
IP	65		
Beam Angle	120°		
Warranty	3Years		

## Application

1. Street lighting.
2. Park lighting.
3. Courtyard lighting.
4. Stadium lighting.
5. Campus lighting.
6. Parking lot lighting



## Dimensional drawing



50W

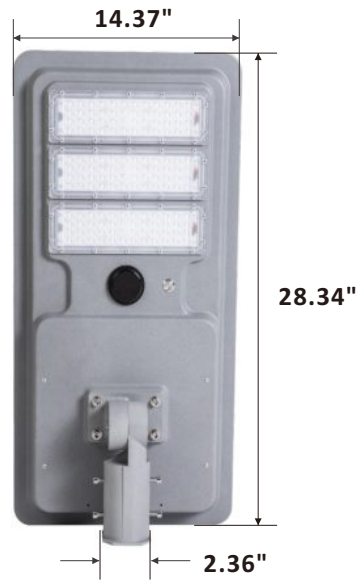

80W



100W

## Detail

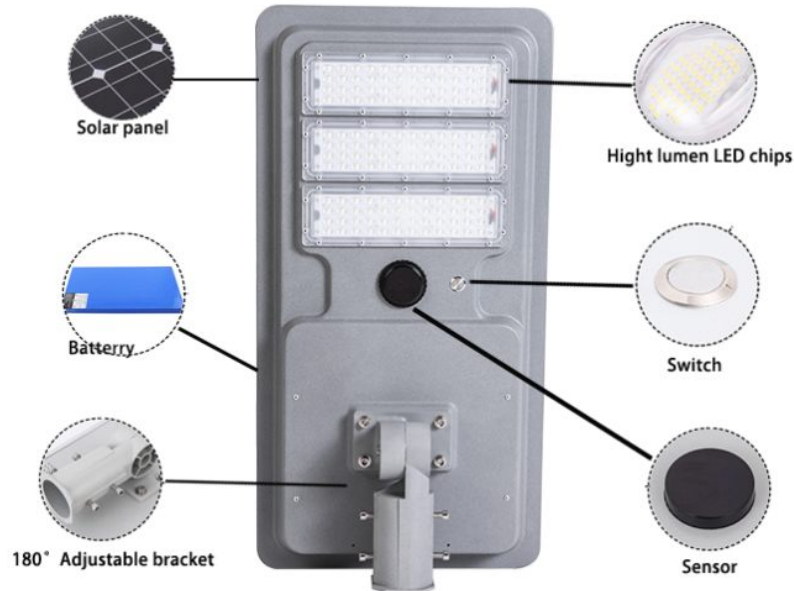

## Ordering Information:

Example: BB-SLD-XXX-A2

Notes: For OEM&ODM orders, pls inquiry sales team.

Area Series	Watts	Version	Control	CCT	Installation	Color
BB-SLD	50W	A2	Blank- Photocell Sensor Motion Sensor	SW-2700K	A- Round pole Mounting B- Bracket Mounting C- Aluminum sleeve mounting	Silver Bronze (Customized)
	80W			WW-3000K		
	100W			NW-4100K		
	DW-5000K					
	CW-5700K					
	SCW-6500K					

Accessories: Expansion screws bag

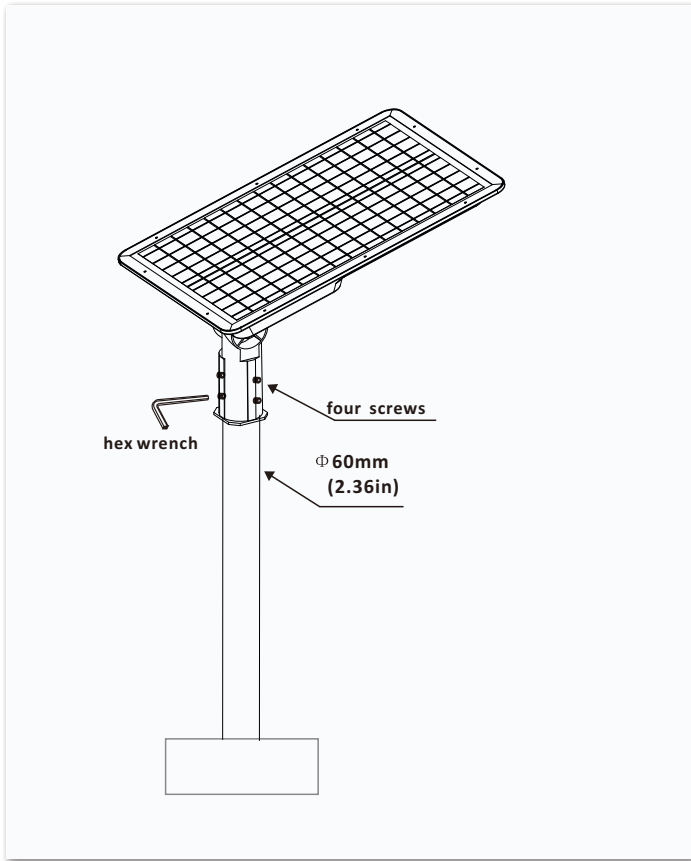

1.Round pole Mounting

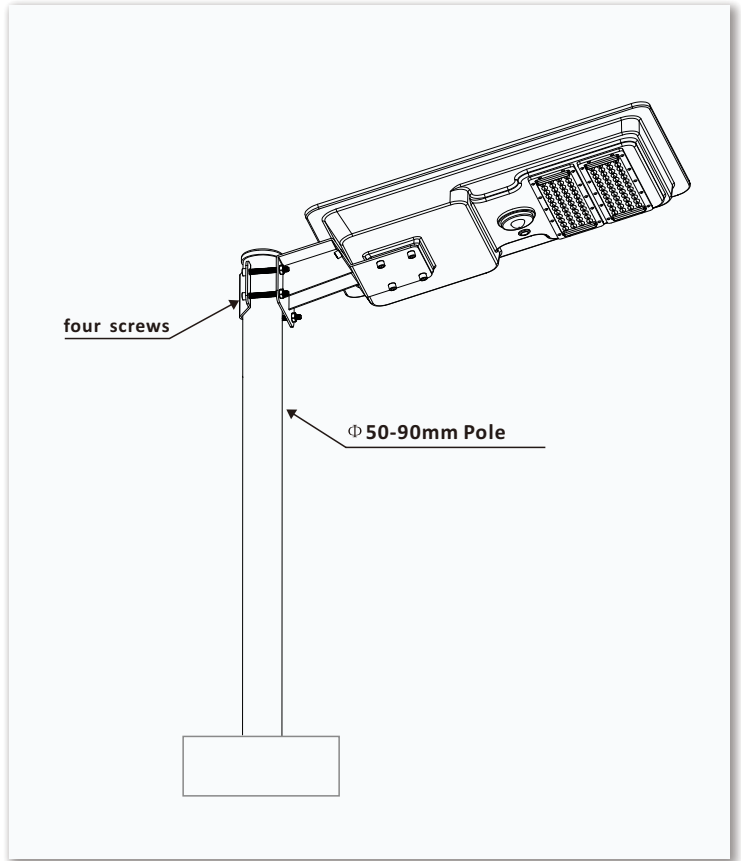

2.Bracket Mounting

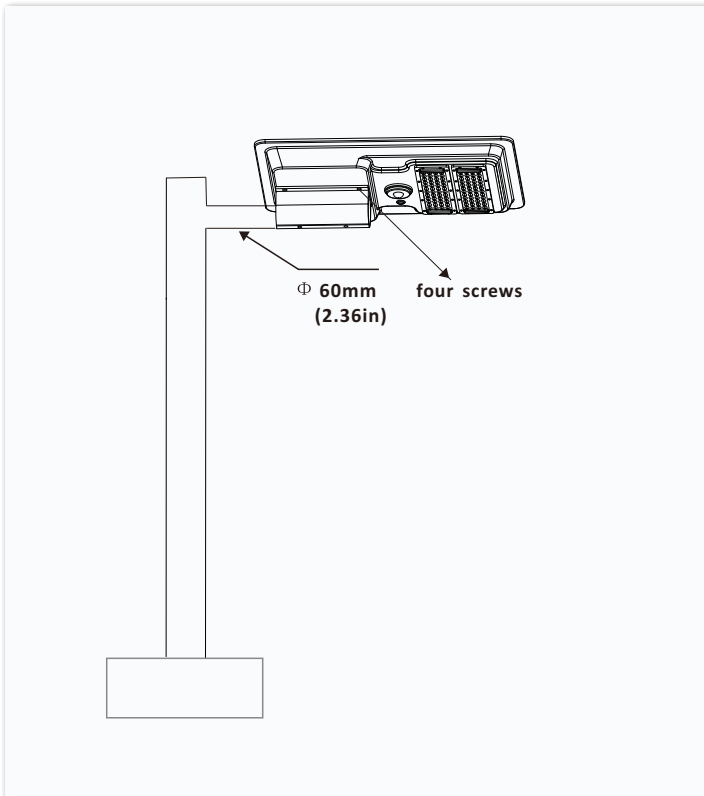

3.Aluminum sleeve mounting

Mounting Bracket:

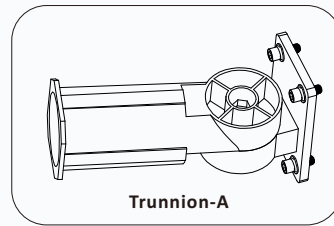

Trunnion-A

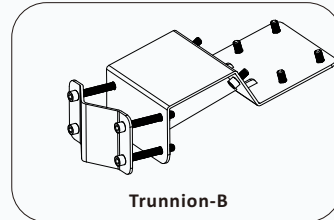

Trunnion-B

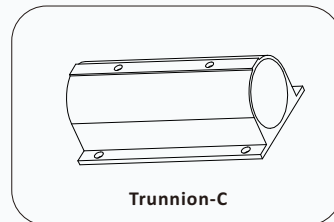

Trunnion-C



## Installation guide

Please contact sales staff if you need help during installation

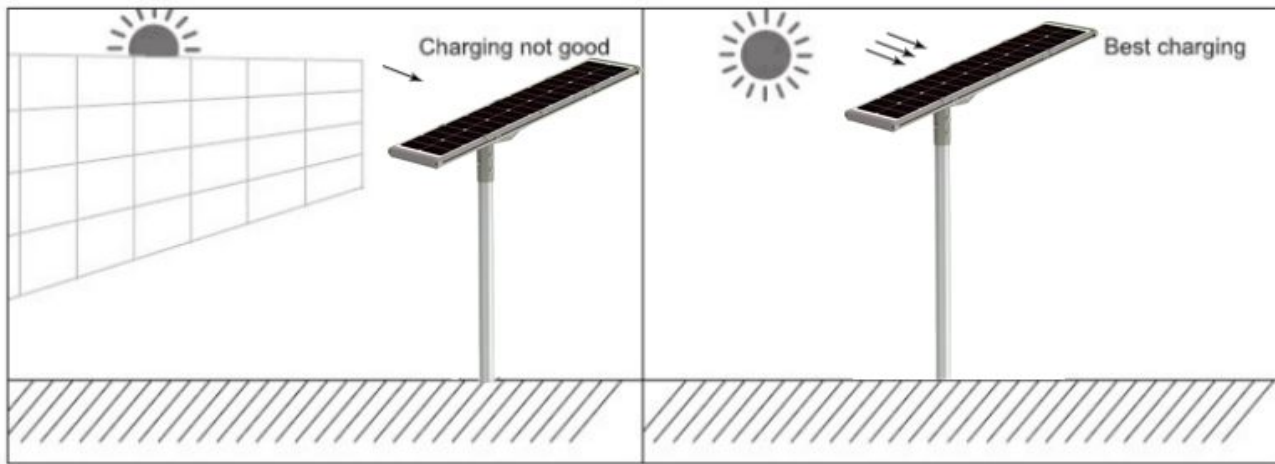
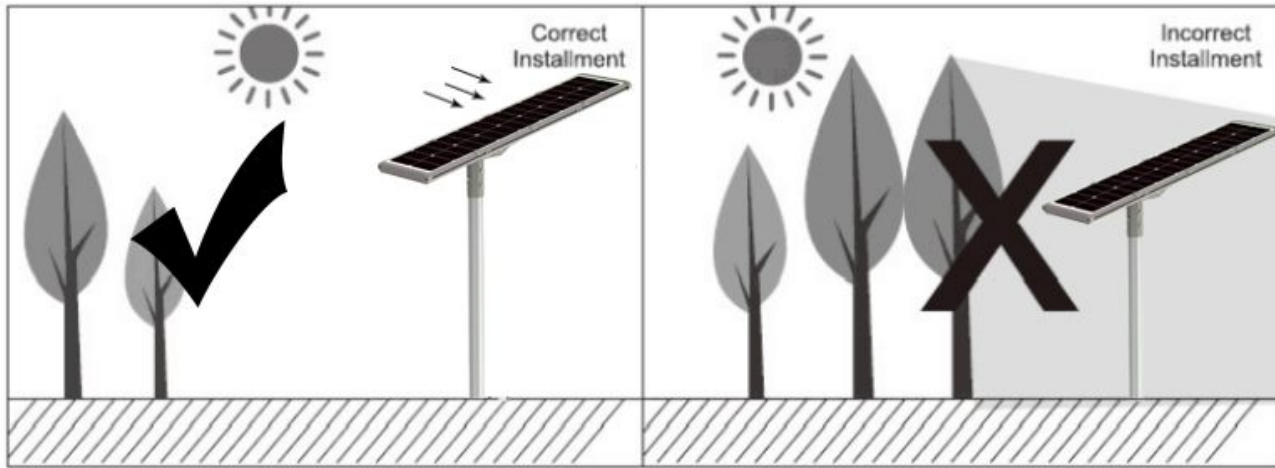

## PROJECTS

By using our 50W street Light to replace 200W Metal Halide bulb for open-parking ground lighting fixtures, the customer is now able to save a lot per month from his electric bill.



Replace

50W LED = 200W MH



## Note :

- Don't take the LED lamp apart.
- Voltage according to the specification.

**PACKING INFO**

Item	Packaging	Carton Size(mm) (L*W*H)	Inner box size	net weight	Gross weight
50W	2pc/CTN	75*29*50CM	72*12*43CM	34.8kg	35.8kg
80W	2pc/CTN	91*29*50CM	86*12*43CM	45.2kg	46.2kg
100W	1pc/CTN	110*45*13CM	110*45*13CM	13.65kg	14.65kg